

## Chapter 2

# Electrostatic Potential and Capacitance

### 2.1 Introduction

#### Electrostatic Potential Energy at a point

Electric potential energy at a point P in an electric field is defined as the work done by the external force in bringing the charge q from infinity to that point.

$$U_{P\infty} = U_P - U_\infty = U_P - 0 = U_P$$

$$U_P = - \int_\infty^P \mathbf{F} \cdot d\mathbf{r}$$

- The work done by an electrostatic field in moving a charge from one point to another depends only on the initial and the final points and is independent of the path taken to go from one point to the other.

#### Electrostatic potential energy difference between two points

Electric potential energy difference between two points in an electric field, can be defined as the work done by an external force in moving (without accelerating) charge q from one point to another in the electric field.

$$\Delta U = U_P - U_R = - \int_R^P \mathbf{F} \cdot d\mathbf{r}$$

**Derivation:-**

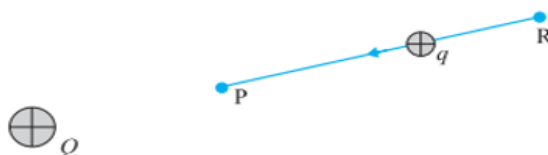

$$W_{RP} = \int_R^P F_{ext} \cdot dr$$

External force,  $F_{ext}$  is equal and opposite to repulsive electric force  $F$ .

$$F_{ext} = -F$$

$$W_{RP} = - \int_R^P F \cdot dr$$

This work done is stored as electrostatic potential energy.

So the potential energy difference between points R and P,

$$\Delta U = U_P - U_R = - \int_R^P \mathbf{F} \cdot d\mathbf{r}$$

## 2.2 Electrostatic Potential

### Electrostatic Potential at a point P

Electrostatic Potential at a point P in an electric field is the work done by an external force in bringing a unit positive charge from infinity to that point.

$$V_P = - \int_{\infty}^P \mathbf{E} \cdot d\mathbf{r}$$

### Electrostatic Potential difference between two points

Electrostatic Potential difference between two points in an electric field is the work done by an external force in bringing a unit positive charge from one point to other in that field.

$$V_P - V_R = \frac{W_{RP}}{q}$$

$$V_P - V_R = \frac{- \int_R^P \mathbf{F} \cdot d\mathbf{r}}{q}$$

$$\mathbf{F} = q\mathbf{E}$$

$$V_P - V_R = \frac{- \int_R^P q\mathbf{E} \cdot d\mathbf{r}}{q}$$

$$V_P - V_R = - \int_R^P \mathbf{E} \cdot d\mathbf{r}$$

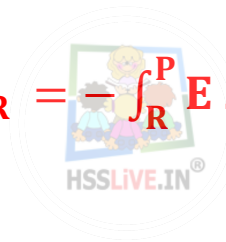

## 2.3 Potential due to a Point Charge

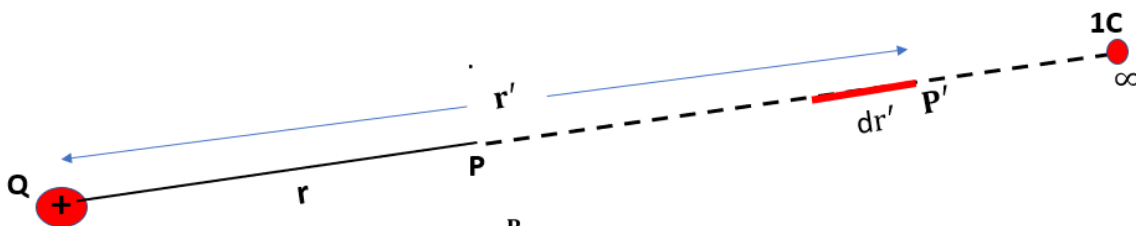

$$V = - \int_{\infty}^P \mathbf{E} \cdot d\mathbf{r}'$$

$$\mathbf{E} = \frac{1}{4\pi\epsilon_0} \frac{Q}{r'^2}$$

$$V = - \int_{\infty}^r \frac{1}{4\pi\epsilon_0} \frac{Q}{r'^2} dr'$$

$$V = - \frac{Q}{4\pi\epsilon_0} \times \left[ \frac{-1}{r'} \right]_{\infty}^r$$

$$V = \frac{1}{4\pi\epsilon_0} \frac{Q}{r}$$

$$V \propto \frac{1}{r}$$

$$v = - \frac{Q}{4\pi\epsilon_0} \left[ \frac{-1}{r} - \frac{-1}{\infty} \right]$$

$$v = - \frac{Q}{4\pi\epsilon_0} \left[ \frac{-1}{r} - 0 \right]$$

## Variation of potential $V$ with $r$ and Electric field with $r$ for a point charge $Q$

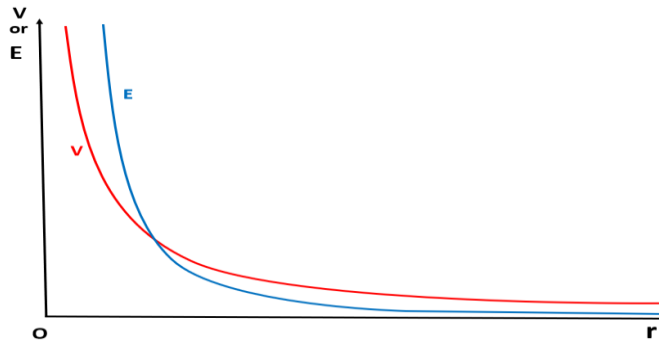
Variation of potential  $V$  with  $r$ Variation of Electric field  $E$  with  $r$ 

$$V = \frac{1}{4\pi\epsilon_0} \frac{Q}{r}$$

$$V \propto \frac{1}{r}$$

$$E = \frac{1}{4\pi\epsilon_0} \frac{Q}{r^2}$$

$$E \propto \frac{1}{r^2}$$

### Example

- (a) Calculate the potential at a point P due to a charge of  $4 \times 10^{-7} \text{ C}$ , located 9 cm away
- (b) Hence obtain the work done in bringing a charge of  $2 \times 10^{-9} \text{ C}$  from infinity to the point P. Does the answer depend on the path along which the charge is brought?

$$(a) \quad V = \frac{1}{4\pi\epsilon_0} \frac{Q}{r}$$

$$= 9 \times 10^9 \times \frac{4 \times 10^{-7}}{0.09}$$

$$\mathbf{V = 4 \times 10^4 \text{ V}}$$

$$(b) \quad W = qV$$

$$= 2 \times 10^{-9} \times 4 \times 10^4$$

$$\mathbf{W = 8 \times 10^{-5} \text{ J}}$$

No, work done will be path independent. Any arbitrary infinitesimal path can be resolved into two perpendicular displacements: One along  $r$  and another perpendicular to  $r$ . The work done corresponding to the later will be zero.

## 2.4 Potential due to an Electric Dipole

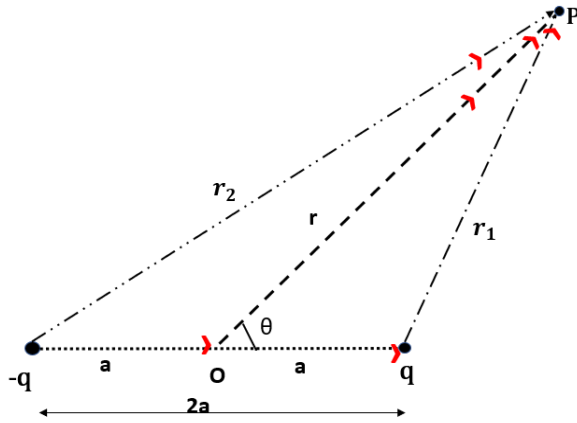

$$V_1 = \frac{1}{4\pi\epsilon_0} \frac{q}{r_1}$$

$$V_2 = \frac{1}{4\pi\epsilon_0} \frac{-q}{r_2}$$

$$V = V_1 + V_2$$

$$V = \frac{1}{4\pi\epsilon_0} \frac{q}{r_1} + \frac{1}{4\pi\epsilon_0} \frac{-q}{r_2}$$

$$V = \frac{q}{4\pi\epsilon_0} \left( \frac{1}{r_1} - \frac{1}{r_2} \right)$$

$$\frac{1}{r_1} - \frac{1}{r_2} = \frac{2a \cos \theta}{r^2}$$

$$V = \frac{q}{4\pi\epsilon_0} \frac{2a \cos \theta}{r^2}$$

$$V = \frac{1}{4\pi\epsilon_0} \frac{p \cos \theta}{r^2}$$

Potential along the axial line

$$\theta = 0$$

$$V = \frac{1}{4\pi\epsilon_0} \frac{p \cos 0}{r^2}$$

$$V = \frac{1}{4\pi\epsilon_0} \frac{p}{r^2}$$

Potential along the equatorial line

$$\theta = 90$$

$$V = \frac{1}{4\pi\epsilon_0} \frac{p \cos 90}{r^2}$$

$$V = 0$$

$$\vec{r} = \vec{r}_1 + \vec{a}$$

$$\vec{r}_1 = \vec{r} - \vec{a}$$

$$\vec{r}_1 = \vec{r} + (-\vec{a})$$

$$\vec{R} = \vec{A} + \vec{B}$$

$$R = \sqrt{A^2 + B^2 + 2AB \cos \theta}$$

$$R^2 = A^2 + B^2 + 2AB \cos \theta$$

$$r_1^2 = r^2 + a^2 - 2ar \cos \theta$$

Since  $a \ll r$ ,  $a$  can be neglected

$$r_1^2 = r^2 - 2ar \cos \theta$$

$$r_1^2 = r^2 \left( 1 - \frac{2a \cos \theta}{r} \right)$$

$$r_1 = r \left( 1 - \frac{2a \cos \theta}{r} \right)^{\frac{1}{2}}$$

$$\frac{1}{r_1} = \frac{1}{r} \left( 1 - \frac{2a \cos \theta}{r} \right)^{-\frac{1}{2}}$$

$$\frac{1}{r_1} = \frac{1}{r} \left( 1 + \frac{a \cos \theta}{r} \right)$$

$$\vec{r}_2 = \vec{r} + (\vec{a})$$

$$\vec{R} = \vec{A} + \vec{B}$$

$$R = \sqrt{A^2 + B^2 + 2AB \cos \theta}$$

$$R^2 = A^2 + B^2 + 2AB \cos \theta$$

$$r_2^2 = r^2 + a^2 + 2ar \cos \theta$$

Since  $a \ll r$ ,  $a$  can be neglected

$$r_2^2 = r^2 + 2ar \cos \theta$$

$$r_2^2 = r^2 \left( 1 + \frac{2a \cos \theta}{r} \right)$$

$$r_2 = r \left( 1 + \frac{2a \cos \theta}{r} \right)^{\frac{1}{2}}$$

$$\frac{1}{r_2} = \frac{1}{r} \left( 1 + \frac{2a \cos \theta}{r} \right)^{-\frac{1}{2}}$$

$$\frac{1}{r_2} = \frac{1}{r} \left( 1 - \frac{a \cos \theta}{r} \right)$$

$$\frac{1}{r_1} - \frac{1}{r_2} = \frac{1}{r} \left( 1 + \frac{a \cos \theta}{r} \right) - \frac{1}{r} \left( 1 - \frac{a \cos \theta}{r} \right)$$

$$\frac{1}{r_1} - \frac{1}{r_2} = \frac{1}{r} + \frac{a \cos \theta}{r^2} - \frac{1}{r} + \frac{a \cos \theta}{r^2}$$

$$\frac{1}{r_1} - \frac{1}{r_2} = \frac{2a \cos \theta}{r^2}$$

## 2.5 Potential due to a System of Charges

By the superposition principle, the potential at a point due to a system of charges is the algebraic sum of the potentials due to the individual charges.

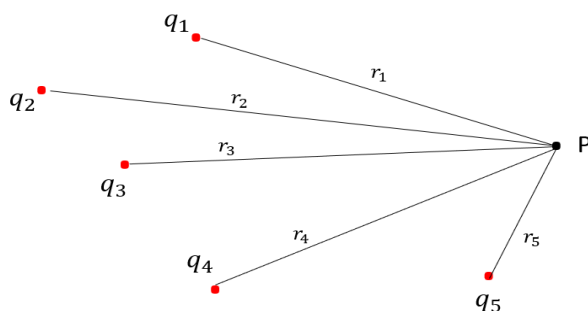

$$V = V_1 + V_2 + \dots + V_n$$

$$V = \frac{1}{4\pi\epsilon_0} \frac{q_1}{r_1} + \frac{1}{4\pi\epsilon_0} \frac{q_2}{r_2} + \dots + \frac{1}{4\pi\epsilon_0} \frac{q_n}{r_n}$$

$$V = \frac{1}{4\pi\epsilon_0} \left( \frac{q_1}{r_1} + \frac{q_2}{r_2} + \dots + \frac{q_n}{r_n} \right)$$

### Potential due to a uniformly charged spherical shell

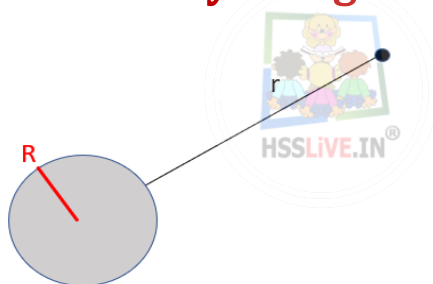

a) The potential at a distance  $r$ , from the shell, where  $r \geq R$   
( $R$ -radius of sphere)

For a uniformly charged spherical shell, the electric field outside the shell is as if the entire charge is concentrated at the centre

$$V = \frac{1}{4\pi\epsilon_0} \frac{q}{r} \quad (r \geq R)$$

b) Inside the shell

Inside the shell the electric field is zero. This implies that the potential is constant inside the shell, which is equal to the value of potential at the surface

$$V = \frac{1}{4\pi\epsilon_0} \frac{q}{R}$$

### Example

Two charges  $3 \times 10^{-8} \text{C}$  and  $-2 \times 10^{-8} \text{C}$  are located 15 cm apart. At what point on the line joining the two charges is the electric potential zero? Take the potential at infinity to be zero.

Let P lies between O and A at a distance x from O,

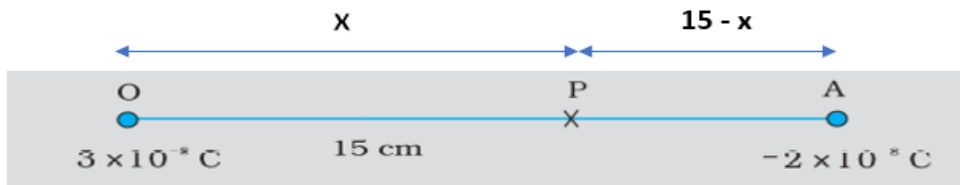

Potential at P due to charge  $3 \times 10^{-8} \text{C}$

$$V_1 = \frac{1}{4\pi\epsilon_0} \frac{3 \times 10^{-8}}{x}$$

Potential at P due to charge  $-2 \times 10^{-8} \text{C}$

$$V_2 = \frac{1}{4\pi\epsilon_0} \frac{-2 \times 10^{-8}}{15-x}$$

Total potential at P,  $V = V_1 + V_2 = 0$

$$\frac{1}{4\pi\epsilon_0} \frac{3 \times 10^{-8}}{x} - \frac{1}{4\pi\epsilon_0} \frac{2 \times 10^{-8}}{15-x} = 0$$

$$\frac{1}{4\pi\epsilon_0} \left[ \frac{3 \times 10^{-8}}{x} - \frac{2 \times 10^{-8}}{15-x} \right] = 0$$

$$\left[ \frac{3}{x} - \frac{2}{15-x} \right] = 0$$

$$\frac{3}{x} = \frac{2}{15-x}$$

$$45 - 3x = 2x$$

$$45 = 5x$$

$$x = 9 \text{ cm}$$

If P lies on the extended line OA,

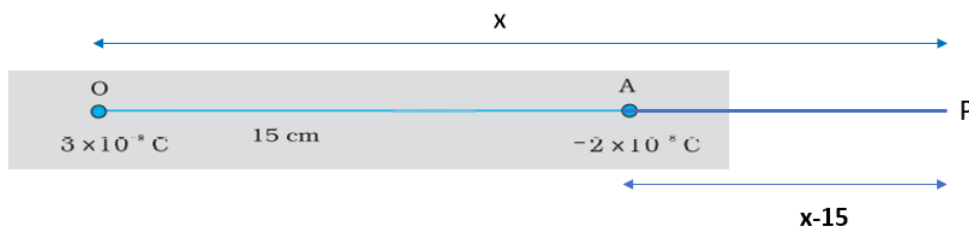

$$\frac{1}{4\pi\epsilon_0} \frac{3 \times 10^{-8}}{x} - \frac{1}{4\pi\epsilon_0} \frac{2 \times 10^{-8}}{x-15} = 0$$

$$\frac{3}{x} = \frac{2}{x-15}$$

$$3x - 45 = 2x$$

$$x = 45 \text{ cm}$$

Thus, electric potential is zero at 9 cm and 45 cm away from the positive charge on the side of the negative charge.

## 2.6 Equipotential Surfaces

An equipotential surface is a surface with a constant value of potential at all points on the surface.

- As there is no potential difference between any two points on an equipotential surface, no work is required to move a test charge on the surface.
- For any charge configuration, equipotential surface through a point is normal to the electric field at that point

### Equipotential surfaces for a single point charge

For a single charge  $q$ , the potential is

$$V = \frac{1}{4\pi\epsilon_0} \frac{q}{r}$$

$V$  is a constant if  $r$  is constant .

Thus, equipotential surfaces of a single point charge are concentric spherical surfaces centred at the charge.

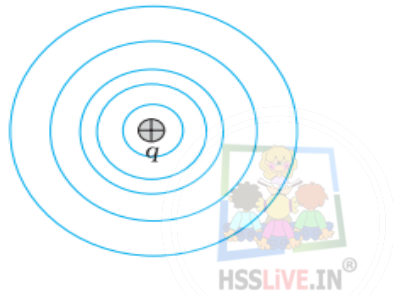

### Equipotential surfaces for a uniform electric field.

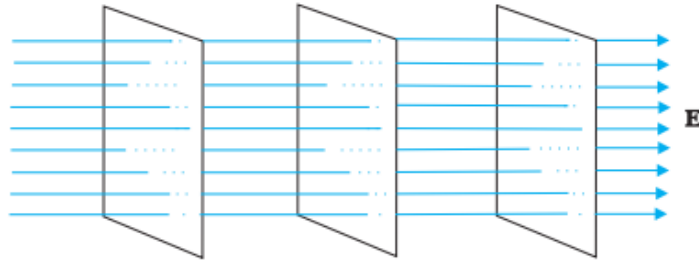

### Equipotential surfaces for a dipole

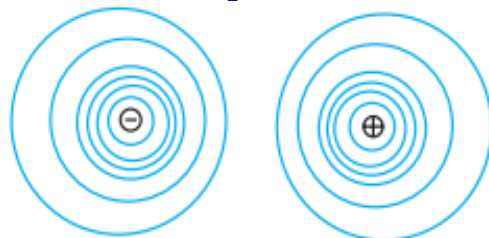

### Equipotential surfaces for two identical positive charges.

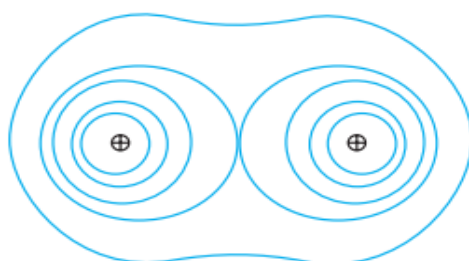

## Relation between electric field and potential

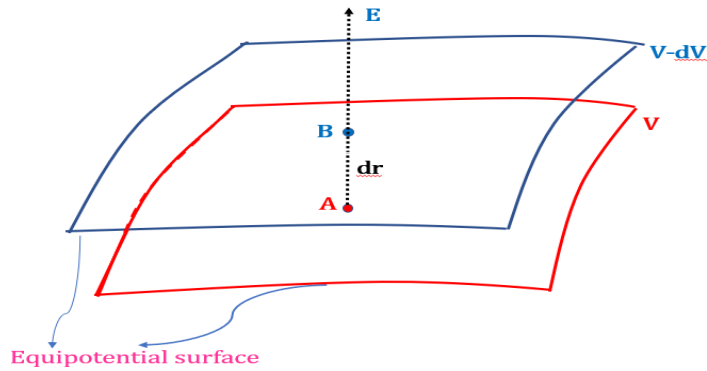

The work done to move a unit positive charge from B to A is

$$dW = F \cdot dr = F dr \cos 180 = -F dr$$

( But  $F = qE$   
 $q = 1$   
 $F = E$  )

$$dW = -E dr$$

This work equals the potential difference,

$$V_A - V_B = V - (V - dV) = dV$$

$$-E dr = dV$$

$$E = -\frac{dV}{dr}$$

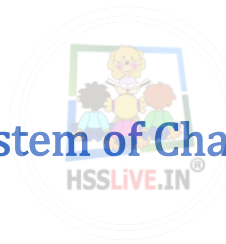

## 2.7 Potential energy of a system of Charges

a) For a system of Two charges

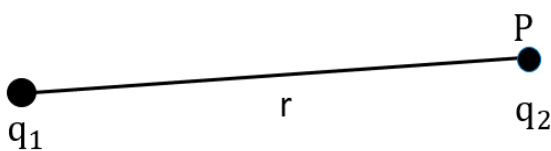

The potential due to the charge  $q_1$  at point P

$$V_1 = \frac{1}{4\pi\epsilon_0} \frac{q_1}{r}$$

The work done in bringing charge  $q_2$  from infinity to the point P is

$$W = qV$$

$$W = q_2 V_1$$

$$W = q_2 \times \frac{1}{4\pi\epsilon_0} \frac{q_1}{r}$$

$$W = \frac{1}{4\pi\epsilon_0} \frac{q_1 q_2}{r}$$

This work gets stored in the form of potential energy of the system. Thus, the potential energy

$$U = \frac{1}{4\pi\epsilon_0} \frac{q_1 q_2}{r}$$

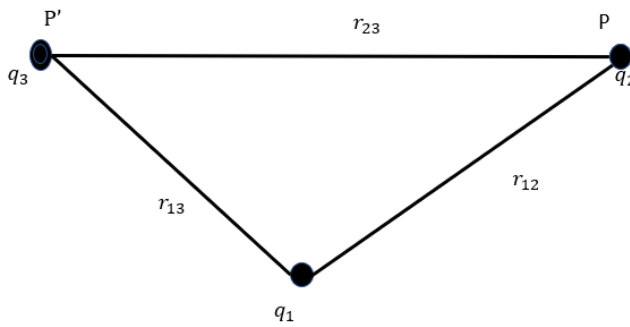
**b) For a system of three charges**

The potential due to the charge  $q_1$  at point P

$$V_1 = \frac{1}{4\pi\epsilon_0} \frac{q_1}{r_{12}}$$

The work done to bring the charge  $q_2$  from infinity to P

$$W_1 = q_2 V_1$$

$$W_1 = \frac{1}{4\pi\epsilon_0} \frac{q_1 q_2}{r_{12}}$$

The total potential at P' due to the charges  $q_1$  and  $q_2$

$$V_2 = \frac{1}{4\pi\epsilon_0} \frac{q_1}{r_{13}} + \frac{1}{4\pi\epsilon_0} \frac{q_2}{r_{23}}$$

$$V_2 = \frac{1}{4\pi\epsilon_0} \left( \frac{q_1}{r_{13}} + \frac{q_2}{r_{23}} \right)$$

The work done to bring the charge  $q_3$  from infinity to P'

$$W_2 = q_3 V_2$$

$$W_2 = \frac{1}{4\pi\epsilon_0} \left( \frac{q_1 q_3}{r_{13}} + \frac{q_2 q_3}{r_{23}} \right)$$

The total workdone in assembling the charges

$$W = W_1 + W_2$$

$$W = \frac{1}{4\pi\epsilon_0} \left( \frac{q_1 q_2}{r_{12}} + \frac{q_1 q_3}{r_{13}} + \frac{q_2 q_3}{r_{23}} \right)$$

This work is equal to the potential energy of the system of three charges  $q_1$ ,  $q_2$  and  $q_3$

$$U = \frac{1}{4\pi\epsilon_0} \left( \frac{q_1 q_2}{r_{12}} + \frac{q_1 q_3}{r_{13}} + \frac{q_2 q_3}{r_{23}} \right)$$

## 2.8 Potential Energy in an External Field

### 1) Potential energy of a single charge

The potential energy of a point charge in an external field is the work done in bringing the charge from infinity to the point.

The external electric field  $E$  and corresponding external potential  $V$  vary from point to point. The potential at infinity is zero.

Thus the work done in bringing the charge  $q$  from infinity to the point  $P$  in the external field is  $qV$ .

This work is stored as potential energy of charge  $q$ .

Potential energy of  $q$  at  $r$  in an external field  $= q V(r)$

### Electron volt

The energy gained by an electron, when it is accelerated by a potential difference of 1 volt is called electron volt (1 eV)

$$1 \text{ eV} = 1.602 \times 10^{-19} \text{ coulomb} \times 1 \text{ volt}$$

$$1 \text{ eV} = 1.602 \times 10^{-19} \text{ J}$$

### 2) Potential energy of a system of two charges in an external field

Consider a system of two charges  $q_1$  and  $q_2$  located at  $r_1$  and  $r_2$ .

The work done in bringing the charge  $q_1$  from infinity to  $r_1 = q_1 V(r_1)$

For bringing the charge  $q_2$  to  $r_2$  work has to be done against the external field and also against the field to  $q_1$ .

The work done in bringing the charge  $q_2$  to  $r_2 = q_2 V(r_2) + \frac{q_1 q_2}{4\pi\epsilon_0 r_{12}}$

The potential energy of the system  $= q_1 V(r_1) + q_2 V(r_2) + \frac{q_1 q_2}{4\pi\epsilon_0 r_{12}}$

### 2.8 Potential energy of a dipole in an external field

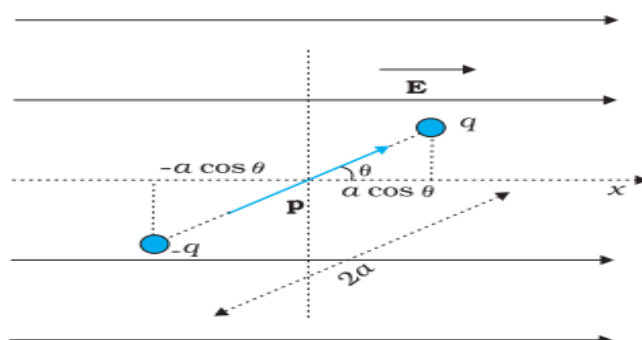

Torque acting on the dipole

$$\vec{\tau} = \vec{p} \times \vec{E}$$

$$\tau = pE \sin \theta$$

The workdone by the external torque

$$dW = \tau_{\text{ext}} d\theta$$

$$dW = pE \sin \theta d\theta$$

$$W = \int_{\theta_0}^{\theta_1} pE \sin \theta d\theta$$

$$W = pE[-\cos \theta]_{\theta_0}^{\theta_1}$$

$$W = pE(-\cos \theta_1 - -\cos \theta_0)$$

$$W = pE(\cos \theta_0 - \cos \theta_1)$$

This work is stored as potential energy of the system

$$U = pE(\cos \theta_0 - \cos \theta_1)$$

If we take  $\theta_0 = \frac{\pi}{2}$ ,

$$U = -pE \cos \theta$$

$$U = -\vec{p} \cdot \vec{E}$$

## 2.9 Electrostatics of conductors

1. Inside a conductor, electrostatic field is zero

A conductor has free electrons. In the static situation, the free charges have so distributed themselves that the electric field is zero everywhere inside.

2. At the surface of a charged conductor, electrostatic field must be normal to the surface at every point.

3. The interior of a conductor can have no excess charge in the static situation.

4. Electrostatic potential is constant throughout the volume of the conductor and has the same value (as inside) on its surface.

5. Electric field at the surface of a charged conductor  $E = \frac{\sigma}{\epsilon_0}$

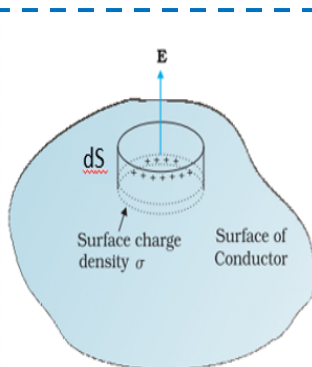

Consider a pill box shaped Gaussian surface to find the electric field at the surface of a charged conductor.

The total flux through the pill box comes only from the outside (circular) cross-section of the pill box

By Gauss's law,

$$E dS = \frac{q}{\epsilon_0}$$

$$E dS = \frac{\sigma dS}{\epsilon_0}$$

$$E = \frac{\sigma}{\epsilon_0}$$

## 6. Electrostatic shielding

The electric field inside a cavity of any conductor is zero. This is known as electrostatic shielding. All charges reside only on the outer surface of a conductor with cavity.

The effect can be made use of in protecting sensitive instruments from outside electrical influence.

### Why it is safer to be inside a car during lightning?

Due to Electrostatic shielding, electric field  $E=0$  inside the car.

So it is safer to sit inside a car than standing outside during lightning.

## 2.10 Dielectrics and polarisation

### Dielectrics

Dielectrics are non-conducting substances. In contrast to conductors, the Dielectric substances may be made of polar or non polar molecules.

### Non polar molecules

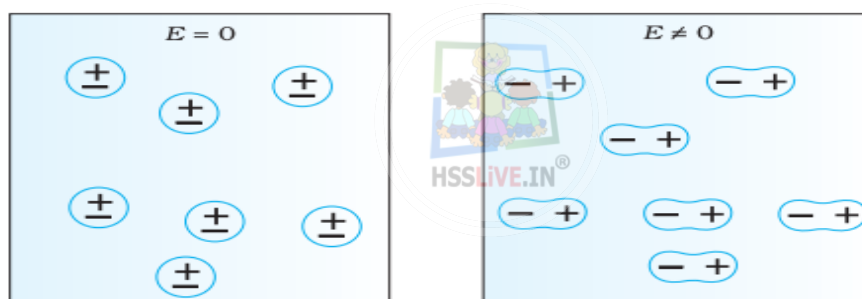

In a non-polar molecule, the centres of positive and negative charges coincide. The molecule then has no permanent (or intrinsic) dipole moment.

Eg: oxygen ( $O_2$ ), hydrogen ( $H_2$ )

In an external electric field, the positive and negative charges of a nonpolar molecule are displaced in opposite directions. The non-polar molecule thus develops an induced dipole moment. The dielectric is said to be polarised by the external field

### Polar molecules

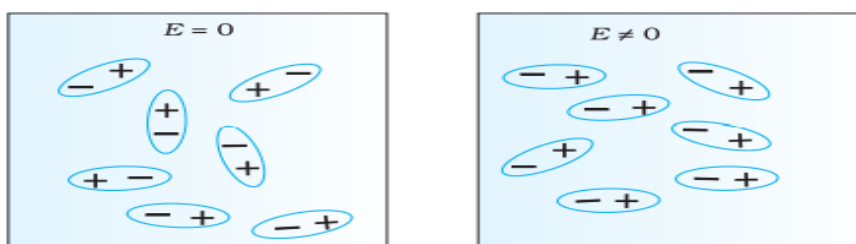

In polar molecules, the centres of positive and negative charges are separated (even when there is no external field). Such molecules have a permanent dipole moment.

Eg: HCl , H<sub>2</sub>O

In the absence of any external field, the different permanent dipoles are oriented randomly ; so the total dipole moment is zero. When an external field is applied, the individual dipole moments tend to align with the field. A dielectric with polar molecules also develops a net dipole moment in an external field.

## Polarisation(P)

The dipole moment per unit volume is called polarisation .

For linear isotropic dielectrics,

$$\mathbf{P} = \chi_e \mathbf{E}$$

where  $\chi_e$  is the electric **susceptibility** of the dielectric medium.

## 2.11 Capacitors and Capacitance

### Capacitor

A capacitor is a system of two conductors separated by an insulator. Capacitor is a charge storing device.

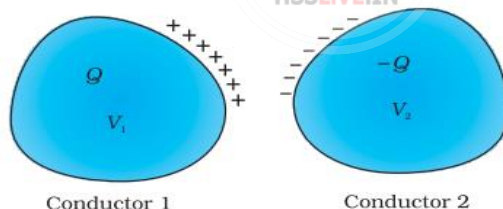

### Capacitance

The potential difference,  $V$  between the two conductors is proportional to the charge ,  $Q$ .

$$Q \propto V$$

$$Q = C V$$

$$C = \frac{Q}{V}$$

The constant  $C$  is called the capacitance of the capacitor.

$C$  is independent of  $Q$  or  $V$ .

The capacitance  $C$  depends only on the geometrical configuration (shape, size, separation) of the system of two conductors .

**SI unit of capacitance is farad.**

$$1 \text{ farad} = 1 \text{ coulomb volt}^{-1}$$

$$1 \text{ F} = 1 \text{ C V}^{-1}$$

Other units are,

$$1 \mu\text{F} = 10^{-6} \text{ F} \quad , \quad 1 \text{ nF} = 10^{-9} \text{ F} \quad , \quad 1 \text{ pF} = 10^{-12} \text{ F}, \text{ etc.}$$

## Symbol of capacitor

### Fixed capacitance

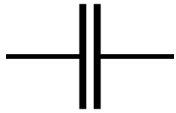

### Variable capacitance

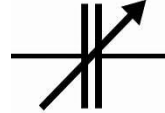

- $C = \frac{Q}{V}$ . For large C, V is small for a given Q. This means a capacitor with large capacitance can hold large amount of charge Q at a relatively small V
- High potential difference implies strong electric field around the conductors. A strong electric field can ionise the surrounding air and accelerate the charges so produced to the oppositely charged plates, thereby neutralising the charge on the capacitor plates, at least partly.
- The maximum electric field that a dielectric medium can withstand without break-down (of its insulating property) is called its dielectric strength; for air it is about  $3 \times 10^6 \text{ Vm}^{-1}$

## 2.12 The parallel plate capacitor

A parallel plate capacitor consists of two large plane parallel conducting plates separated by a small distance.

### Capacitance of a parallel plate capacitor

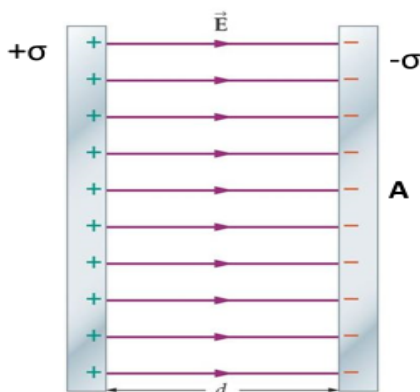

Capacitance,  $C = \frac{Q}{V}$

$$Q = \sigma A$$

$$V = Ed$$

$$E = \frac{\sigma}{\epsilon_0}$$

$$V = \frac{\sigma d}{\epsilon_0}$$

$$C = \frac{\sigma A}{\frac{\sigma d}{\epsilon_0}}$$

$$C = \frac{\epsilon_0 A}{d}$$

## Capacitance can be increased,

- By increasing the area of the plates.
- By decreasing the distance between the plates.
- By introducing a dielectric medium between the plates.

### 2.13 Effect of dielectric on capacitance

The capacitance of a parallel plate capacitor when the medium between the plates is air,

$$C_{\text{air}} = \frac{\epsilon_0 A}{d}$$

When dielectric medium of dielectric constant  $K$  is placed between the plates, the capacitance ,

$$C_{\text{med}} = \frac{K\epsilon_0 A}{d}$$

The capacitance increases  $K$  times, where  $K$  is the dielectric constant.

$$C_{\text{med}} = K C_{\text{air}}$$

### Definition of dielectric constant in terms of capacitance

$$\frac{C_{\text{med}}}{C_{\text{air}}} = \frac{\frac{K\epsilon_0 A}{d}}{\frac{\epsilon_0 A}{d}} = K$$

$$K = \frac{C_{\text{med}}}{C_{\text{air}}}$$

The dielectric constant of a substance is the factor by which the capacitance increases from its vacuum value, when a dielectric is inserted between the plates.

### 2.14 Combination of Capacitors

#### Capacitors In Series

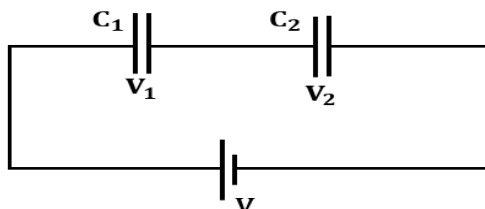

In series combination the charge  $Q$  is same and potential drop is different in each capacitor. The total potential drop  $V$  across the combination is

$$V = V_1 + V_2$$

$$V = \frac{Q}{C_1} + \frac{Q}{C_2} \text{ -----(1)}$$

If the two capacitors are replaced by a single capacitor of capacitance  $C$  with the same charge  $Q$  and potential difference  $V$ .

$$V = \frac{Q}{C} \text{ ----- (2)}$$

Equating eq (1) &

$$\frac{Q}{C} = \frac{Q}{C_1} + \frac{Q}{C_2}$$

$$\frac{1}{C} = \frac{1}{C_1} + \frac{1}{C_2}$$

- For n capacitors in series,  $\frac{1}{C} = \frac{1}{C_1} + \frac{1}{C_2} + \dots + \frac{1}{C_n}$
- If all the capacitors have the same value,  $C_1 = C_2 = \dots = C_n = C$

$$\frac{1}{C'} = \frac{n}{C} \quad , \quad C' = \frac{C}{n}$$

eg:- If  $C = 1\mu\text{F}$      $n = 10$

$$C' = \frac{C}{n} = \frac{1\mu\text{F}}{10} = 0.1\mu\text{F}$$

The effective capacitance decreases when capacitors are connected in series. In series combination the effective capacitance will be smaller than the smallest among individual capacitors.

### Example

Find the effective capacitance of the combination.

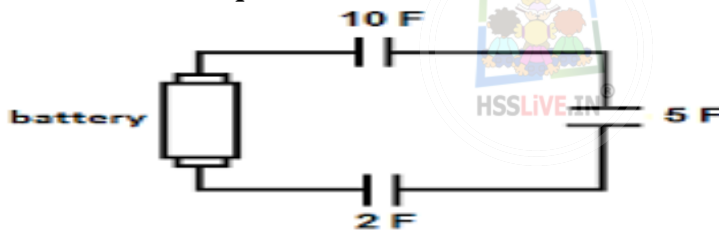

$$\frac{1}{C} = \frac{1}{C_1} + \frac{1}{C_2} + \frac{1}{C_3}$$

$$\frac{1}{C} = \frac{1}{2\text{F}} + \frac{1}{5\text{F}} + \frac{1}{10\text{F}} = \frac{8}{10\text{F}}$$

$$C = \frac{10\text{F}}{8} = 1.25\text{F}$$

### Capacitors In Parallel

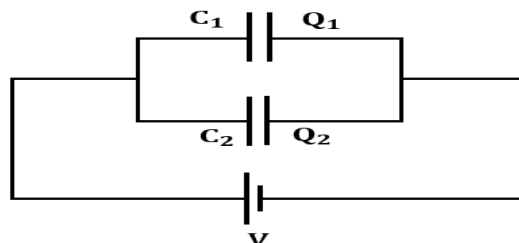

In parallel connection, the same potential drop across both the capacitors, but the charges are different.

$$Q = Q_1 + Q_2$$

$$Q = C_1V + C_2V \text{ ----- (1)}$$

If the two capacitors are replaced by a single capacitor of capacitance  $C$  with the same charge  $Q$  and potential difference  $V$ .

$$Q = CV \text{ ----- (2)}$$

From eq(1) & (2)  $CV = C_1V + C_2V$

$$C = C_1 + C_2$$

- For  $n$  capacitors in parallel,  $C = C_1 + C_2 + C_3 + \dots + C_n$
- If all the capacitors have the same value,  $C_1 = C_2 = C_3 = \dots = C_n = C$

$$C' = nC$$

Eg: If  $C = 1\mu\text{F}$   $n = 10$

$$C' = nC = 10 \times 1\mu\text{F} = 10\mu\text{F}$$

The effective capacitance increases when capacitors are connected in parallel. In parallel combination the effective capacitance will be greater than the greatest among individual capacitors.

### Example

Find the effective capacitance of the combination.

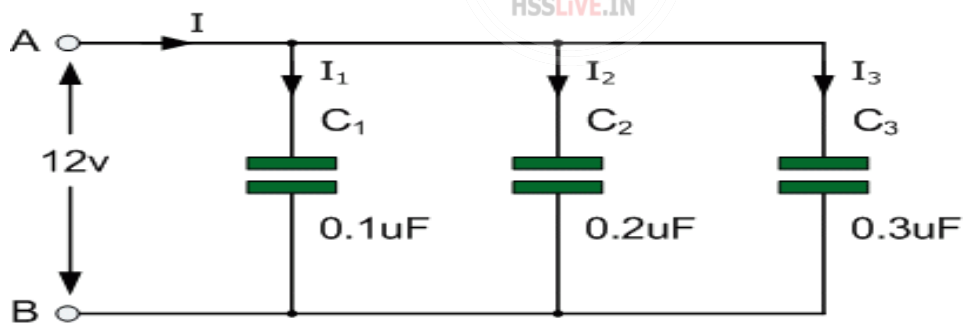

$$C = C_1 + C_2 + C_3$$

$$C = 0.1 \mu\text{F} + 0.2 \mu\text{F} + 0.3 \mu\text{F}$$

$$C = 0.6 \mu\text{F}$$

1) Find the equivalent capacitance of capacitors given in the network

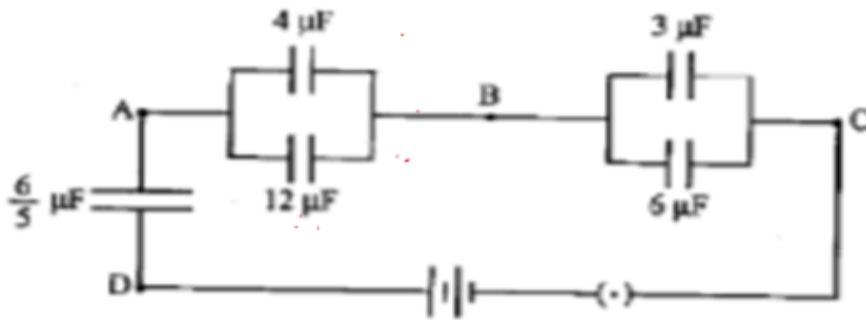

4 μF and 12 μF are connected in parallel.

$$C' = C_1 + C_2$$

$$C' = 4\mu\text{F} + 12\mu\text{F}$$

$$C' = 16\mu\text{F}$$

3 μF and 6 μF are connected in parallel.

$$C'' = C_1 + C_2$$

$$C'' = 3\mu\text{F} + 6\mu\text{F}$$

$$C'' = 9\mu\text{F}$$

6/5 μF, 16 μF and 9 μF are connected in series

$$\frac{1}{C} = \frac{1}{C_1} + \frac{1}{C_2} + \frac{1}{C_3}$$

$$\frac{1}{C} = \frac{1}{6/5 \mu\text{F}} + \frac{1}{16\mu\text{F}} + \frac{1}{9\mu\text{F}}$$

$$\frac{1}{C} = \frac{5}{6 \mu\text{F}} + \frac{1}{16\mu\text{F}} + \frac{1}{9\mu\text{F}} = 1.0069$$

$$C = \frac{1}{1.0069}$$

$$C = 0.99\mu\text{F}$$

2) Two capacitors are connected as shown in figure. The equivalent capacitance of the combination is 4 μF.

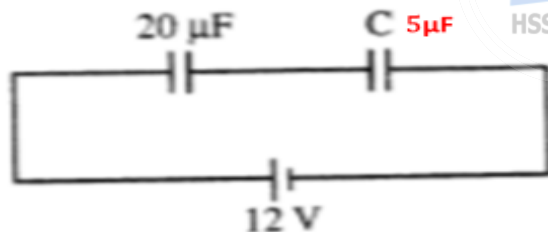

(a) Calculate the value of C

$$\frac{1}{C'} = \frac{1}{C_1} + \frac{1}{C_2}$$

$$\frac{1}{4\mu\text{F}} = \frac{1}{20\mu\text{F}} + \frac{1}{C}$$

$$\frac{1}{C} = \frac{1}{4\mu\text{F}} - \frac{1}{20\mu\text{F}}$$

$$\frac{1}{C} = \frac{4}{20\mu\text{F}} \quad C = 5\mu\text{F}$$

(b) Calculate the charge on each capacitor.

$$C' = \frac{Q}{V}$$

$$Q = C'V$$

$$Q = 4\mu\text{F} \times 12$$

$$Q = 48 \mu\text{C}$$

(c) What will be the potential drop across each capacitor?

The potential drop across 20 μF

$$V_1 = \frac{Q}{C_1}$$

$$V_1 = \frac{48\mu\text{C}}{20\mu\text{F}}$$

$$V_1 = 2.4 \text{ V}$$

The potential drop across 5 μF

$$V_2 = \frac{Q}{C_2}$$

$$V_2 = \frac{48\mu\text{C}}{5\mu\text{F}}$$

$$V_2 = 9.6 \text{ V}$$

3) Three capacitors are connected to a 12V battery as shown in figure

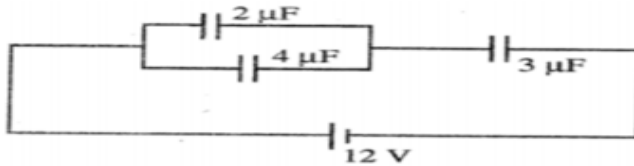

a) What is the effective capacitance of the combination?

$2\mu\text{F}$  and  $4\mu\text{F}$  are connected in parallel.

$$C' = C_1 + C_2$$

$$C' = 2\mu\text{F} + 4\mu\text{F}$$

$$C' = 6\mu\text{F}$$

$6\mu\text{F}$  and  $3\mu\text{F}$  are connected in series

$$\frac{1}{C} = \frac{1}{C_1} + \frac{1}{C_2} \quad C = \frac{C_1 C_2}{C_1 + C_2} = \frac{6\mu \times 3\mu}{6\mu + 3\mu}$$

$$C = \frac{18\mu \times \mu}{9\mu}$$

$$C = 2\mu\text{F}$$

b) What is the potential difference across the  $2\mu\text{F}$  capacitor?

$$V = \frac{Q}{C}$$

$$Q = CV$$

$$Q = 2\mu \times 12$$

$$Q = 24\mu\text{C}$$

$$V = \frac{Q}{C}$$

$$V = \frac{24\mu}{6\mu}$$

$$V = 4\text{V}$$

4) What is area of plates of a  $0.1\mu\text{F}$  parallel plate air capacitor, given that the separation between the plates is  $0.1\text{mm}$

$$C = \frac{\epsilon_0 A}{d}$$

$$A = \frac{Cd}{\epsilon_0} = \frac{0.1 \times 10^{-6} \times 0.1 \times 10^{-3}}{8.85 \times 10^{-12}}$$

$$= 10.47 \times 10^3 \text{ m}^2$$

HSSLIVE.IN®

5) A parallel plate capacitor with air between plates has a capacitance of  $8\mu\text{F}$ . What will be the capacitance if distance between the plates is reduced by half and the space between is filled with a medium of dielectric constant 5.

$$C = \frac{\epsilon_0 A}{d} = 8\mu\text{F}$$

$$C' = \frac{K\epsilon_0 A}{d/2} = 2K \frac{\epsilon_0 A}{d} = 2 \times 5 \times 8\mu\text{F} = 80\mu\text{F}$$

## 2.15 Energy Stored in a Capacitor

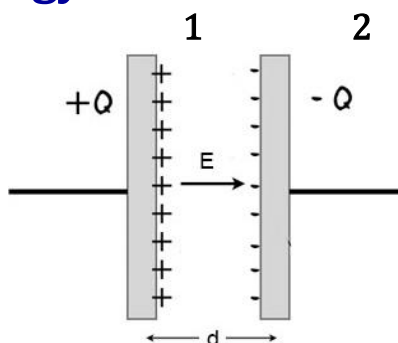

Work done to move a charge  $dq$  from conductor 2 to conductor 1

$$dW = \text{Potential} \times \text{Charge}$$

$$dW = V dq$$

$$dW = \frac{q}{C} dq$$

The total work done to attain a charge  $Q$  on conductor 1, is

$$W = \int_0^Q dW = \int_0^Q \frac{q}{C} \times dq$$

$$W = \frac{Q^2}{2C}$$

The work stored as potential energy in the electric field between the plates.

$$\text{Energy } U = \frac{Q^2}{2C}$$

Energy stored in a capacitor can also be expressed as

$$U = \frac{Q^2}{2C}$$

$$C = \frac{Q}{V}$$

$$Q = CV$$

$$U = \frac{C^2 V^2}{2C}$$

$$U = \frac{1}{2} CV^2$$

$$U = \frac{Q^2}{2C}$$

$$C = \frac{Q}{V}$$

$$U = \frac{Q^2}{2 \frac{Q}{V}}$$

$$U = \frac{1}{2} QV$$

## Energy Stored in a Capacitor

### Graphical method

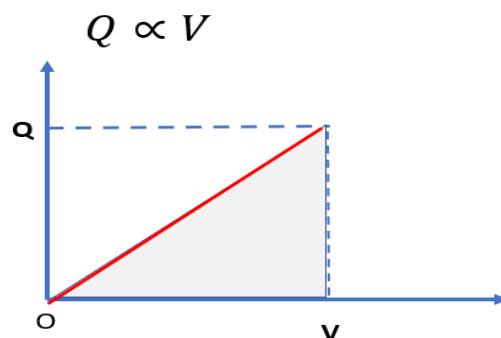

Area under the graph =  $\frac{1}{2} QV = \text{Energy}$

Area under  $Q$ - $V$  graph gives energy stored in a capacitor

## Energy Density of a capacitor

Energy density is the energy density is the energy stored per unit volume

$$U = \frac{1}{2} CV^2$$

$$C = \frac{\epsilon_0 A}{d} \text{-----(1)}$$

$$V = E d$$

$$E = \frac{\sigma}{\epsilon_0}$$

$$V = \frac{\sigma}{\epsilon_0} d \text{-----(2)}$$

$$U = \frac{1}{2} \frac{\epsilon_0 A}{d} \frac{\sigma^2 d^2}{\epsilon_0^2}$$

$$U = \frac{1}{2} \epsilon_0 \frac{\sigma^2}{\epsilon_0^2} Ad$$

$$U = \frac{1}{2} \epsilon_0 E^2 Ad$$

Energy density =  $\frac{\text{Energy stored}}{\text{volume}}$

$$u = \frac{U}{Ad}$$

$$u = \frac{\frac{1}{2} \epsilon_0 E^2 Ad}{Ad}$$

$$u = \frac{1}{2} \epsilon_0 E^2$$

